

hy-gain

308 Industrial Park Road
Starkville, MS 39759 USA
Ph: (662) 323-9538 FAX: (662) 323-6551

TH3-MK4 Triband HF Beam 3-Element 10, 15, 20 Meter

INSTRUCTION MANUAL

General Description

The Hy-Gain TH3-MK4 is a 3 element, 3 band beam antenna designed for operation on the 10, 15, and 20 meter amateur bands. The TH3-MK4 uses Hy-Gain's full power "Hy-Q" traps, and HyGain's rugged boom-to-mast bracket. The TH3MK4 will mount on a standard 2" O.D. mast and can be rotated with Hy-Gain's CD-4511 or HAMIV rotators. All **hardware is stainless steel.**

New features in the TH3-MK4 compared to the TH3-MK3 include - all stainless steel hardware, a new Beta-match, 3 settings, and a 4 piece boom - ideal for DXpeditions!

Specifications

Electrical:

Gain (ave.)	5.8 dBd (8.0 dBi)
Front-To-Back Ratio (max.)	25 dB
Maximum Power	1500 Watts PEP
VSWR at resonance	Less than 1.5:1
Input Impedance	50 ohms
Matching System	Beta (DC Ground)

Mechanical:

Boom Length	14 ft. (4.3m)
Boom Diameter	2 in. (51mm)
Longest Element	27' 5" (8.36m)
Turning Radius	15'4" (4.67m)
Accepts Mast	1.9 to 2.5in. (48 to 64mm)
Net Weight	35 lb. (16 kg)
Shipping Weight	40 lb. (18 kg)
Maximum Wind Survival	95mph (153 kmph)
Wind Surface Area (max.)	4.6 sq. ft. (0.4 sq. m)
Wind Load at 80 MPH	118 lb. (53.6 kg)
Hardware	All Stainless Steel
Suitable Rotators	Hy-Gain CD-45II or HAM-IV

Preparation for Assembly

FOR OUR OVERSEAS CUSTOMERS: The United States uses American units of measurement. Please see page 12 of this manual for American-to-Metric conversion. Most illustrations include both American and Metric dimensions.

When unpacking your antenna, check inside of all tubing for smaller tubes and traps. To conserve space and protect traps, these parts are packed this way. Check all parts against the parts list to ensure no parts are missing.

Choose a large, clear area to assemble your TH3-MK4 antenna. The area must be at least 14' x 28' (4.3 m x 8.6 m). You may wish to use a temporary mast to support the boom during assembly. All tubing supplied with the TH3-MK4 telescopes together. Make all measurements to the given dimensions, plus or minus no more than 1/8 inch (3 mm).

The following tools are required for easy assembly of the TH3-MK4

Tape Measure – 12 foot

Nut Drivers – 5/16", 3/8", 7/16", 1/2"

(8,9,5,11,12.7mm)

Assembly of the Boom

Select the boom-to-mast clamps (Items 5 and 6). Loosely assemble them on the drilled ends of the two boom sections (Item 8) using the 1/4"-20 x 3/4" bolts, 1/4" nuts and lockwashers (Items 26, 28, and 29). Secure the booms to the bracket using the two 5/16"-18 x 2 3/4" screws, nuts and lockwashers (Items 36, 38, and 39). Tighten these six bolts securely.

Assemble the two cast aluminum brackets (Item 1) on your temporary mast about 4 feet (1 m) above ground. Secure the two brackets together using the two 5/16"-18 x 3" bolts, nuts and lockwashers. Tighten these two bolts evenly until the brackets are snug.

Attach the boom assembly to these two brackets using the four 5/16"-18 x 5" bolts, nuts and lockwashers (Items 33, 38, and 39). Tighten these four bolts just enough to hold the weight of the

Assemble the remaining two boom sections (Item 7) to the ends of the assembled boom using 1/4"-20 x 2 1/2" screws, nuts, and lockwashers. Tighten securely.

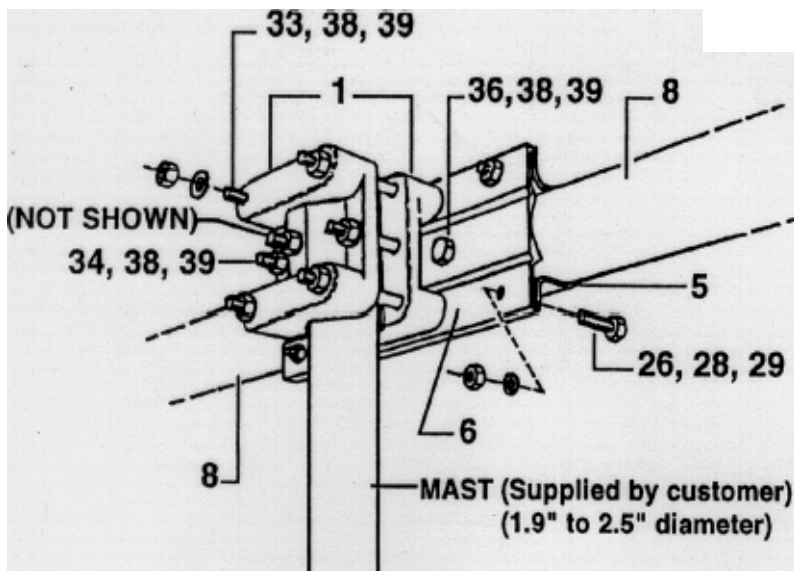

Figure 1 Boom-to-Mast Bracket

Item No.	Description
1	Mast Bracket, cast aluminum
5	Clamp, boom to bracket
6	Bracket, Casting to boom
7	Tube, 2" x.049 x 4212"
8	Tube, 2" x.049 x 4612", swaged
26	Bolt 1/4"-20 x 3/4", hex head, stainless steel
28	Nut, 1/4"-20, hex, stainless steel
29	Lockwasher, 1/4", internal, stainless steel
33	Bolt, 5/16"-18 x 5", hex head, stainless steel
34	Bolt 5/16"-18 x 3", hex head, stainless steel
36	Bolt, 5/16"-18 x 2 3/4", hex head, stainless steel
38	Nut, 5/16"-18, hex, stainless steel
39	Lockwasher, 5/16", split, stainless steel

Element-to-Boom Brackets

There are two sizes of element-to-boom brackets supplied. The largest (Item 4) has a 1 1/2" I.D., and is used only on the driven element. The remaining brackets (Item 3) have a 1 1/4" I.D., and are used on the reflector and director elements.

Assemble the brackets as shown in Figure 2 and position them on the boom as shown in Figure 8. It is easier to assemble the brackets on the boom at the correct location, rather than try to slide them on the boom. If you are going to leave this assembly unattended for more than 15 minutes, we suggest that you tighten the eight (8) bolts on each bracket, so that they do not vibrate off. Do not tighten the two (2) anchor bolts (Item 25) until the elements are installed and aligned.

Item No.	Description
3	Bracket, Element-to-boom, #13
4	Bracket, Element-to-boom, #14
14	Tubing Any., aluminum, RDE-1, FDE-1, & D-Insulator, driven element
23	Insulator, driven element
25	Bolt, 1/4"-20 x 3/8", hex head, stainless steel
26	Bolt, 1/4"-20 x 3/4", hex head, stainless steel
27	Nut, 1/4"-20, square, stainless steel
28	Nut, 1/4"-20, hex, stainless steel
29	Lockwasher, 1/4", internal, stainless steel

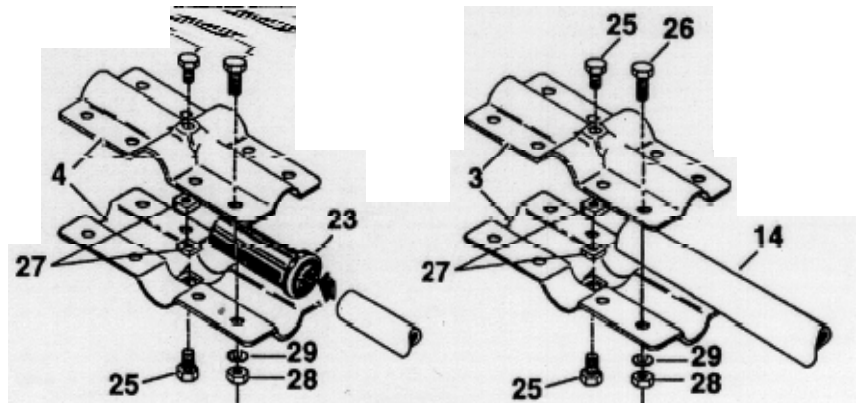

Figure 2

Element-to-Boom Brackets

Tubing Clamp Assembly

Select the proper size tubing clamps as shown in Figure 3. When installing the clamps, place the clamp near the tube end with the top of the clamp over the slot in the tube as shown.

After adjustment of the tubing lengths, tighten the clamp with a 5/16 inch (8 mm) nut driver until the tubing will not twist or telescope. DO NOT overtighten!

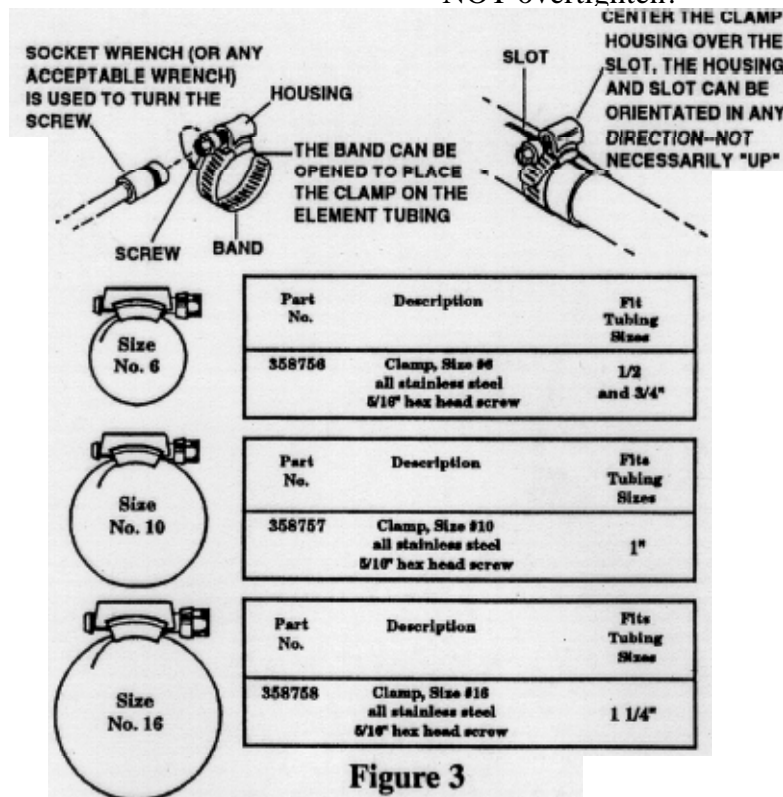

Figure 3
Tubing Clamp Assembly

Settings

The TH3-MK4 is supplied with 3 settings - CW, Middle, and Phone. Choose one of these settings to use in assembling this antenna. Typical VSWR curves shown in Figure 4 will help you decide which setting to use.

The VSWR curves are typical for this antenna mounted 70 feet (21.3 m) above ground. Similar curves can be expected for this antenna mounted between 30 feet (9.1 m) and 100 feet (30.5 m) above ground. Do not try to tune this antenna for low VSWR at ground level!

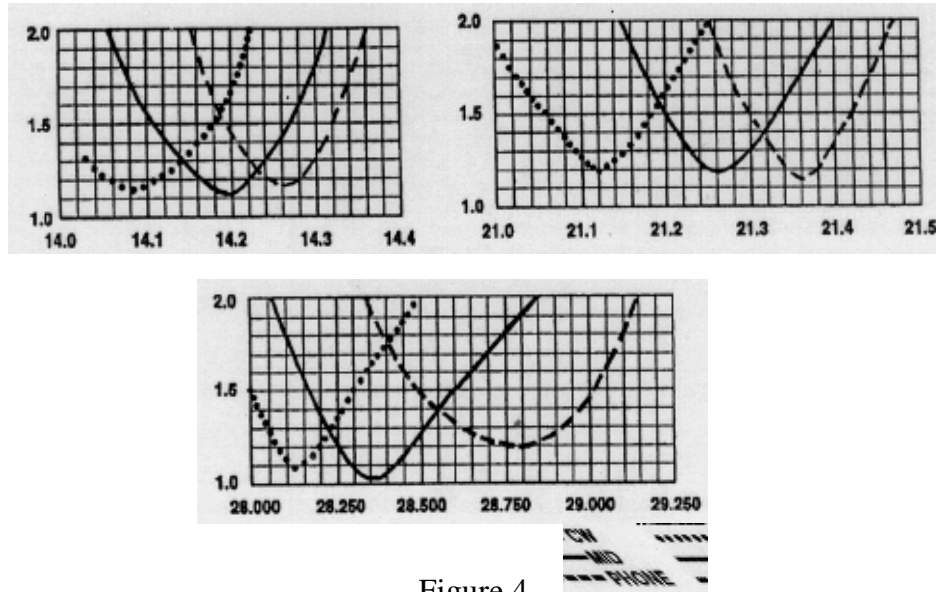

Figure 4
VSWR Curves

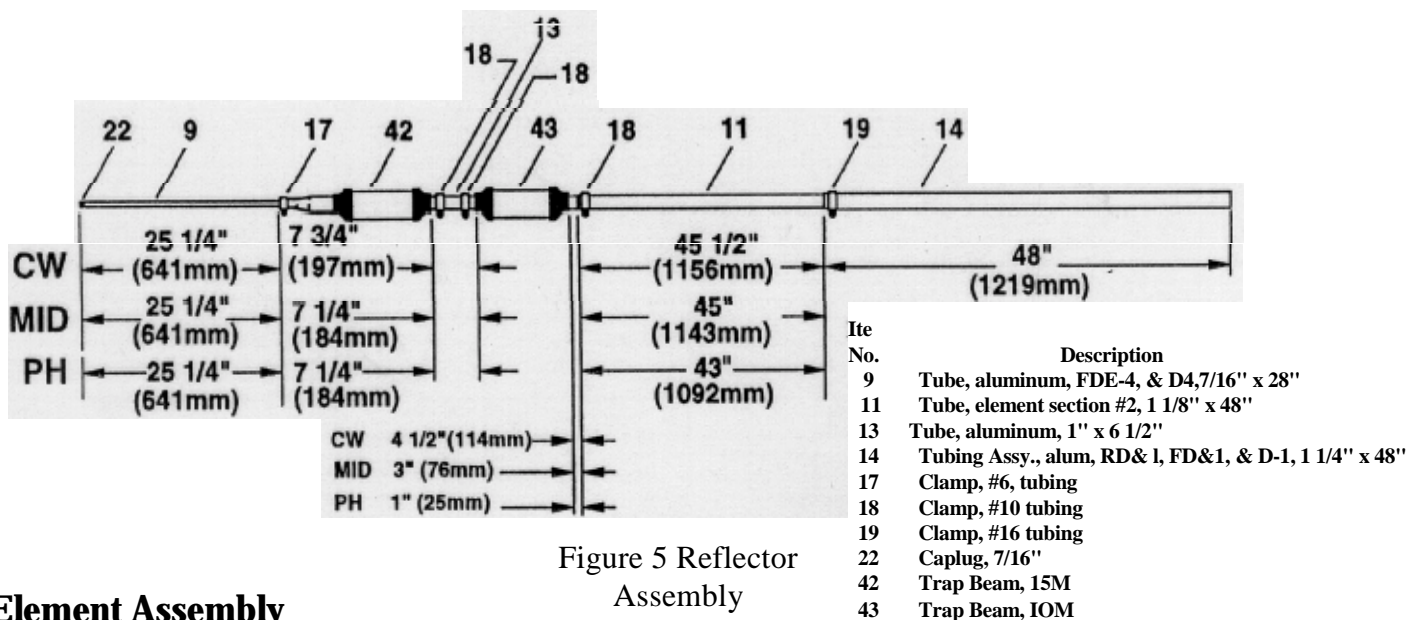

Figure 5 Reflector
Assembly

Element Assembly

Select the remaining tubing parts, traps, and tubing clamps. Assemble each element as shown in Figures 5, 6, and 7. Install all traps with drain holes on the bottom and labeled end toward the boom. There are two kinds of 15 meter traps: Part No. 878694 is used on the reflector and director and Part No. 878637 is used on the Driven Element.

Mark each element with an indelible marker. Use "R" for the reflector sections, "DE" for the driven element sections, and "DIR" for the director sections. Install the driven element insulators (Item 23) and the 1 1/4" tubing clamp assemblies onto the large ends of the driven element sections. See Figure 9 for clamp assembly details.

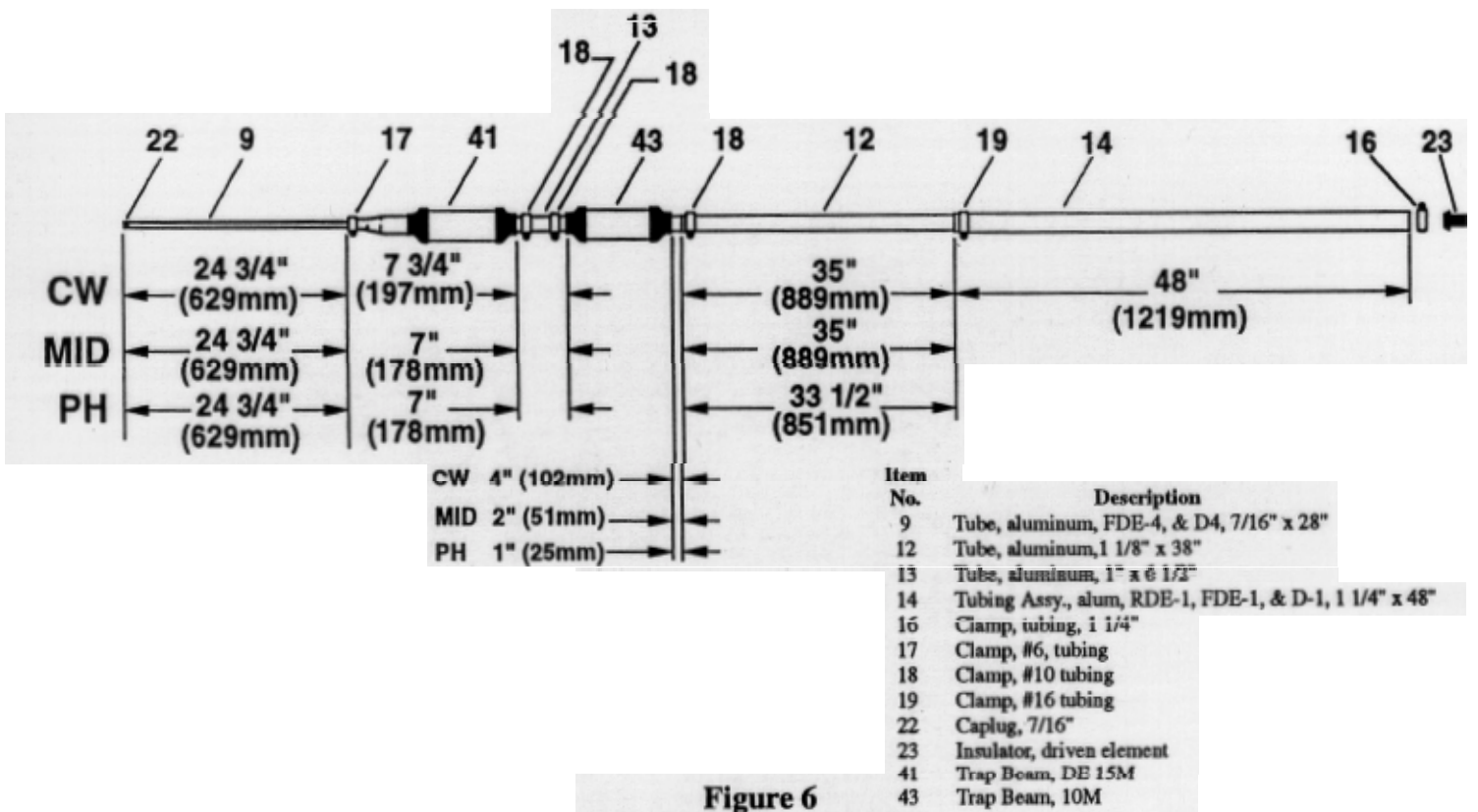

Figure 6
Driven Element Assembly

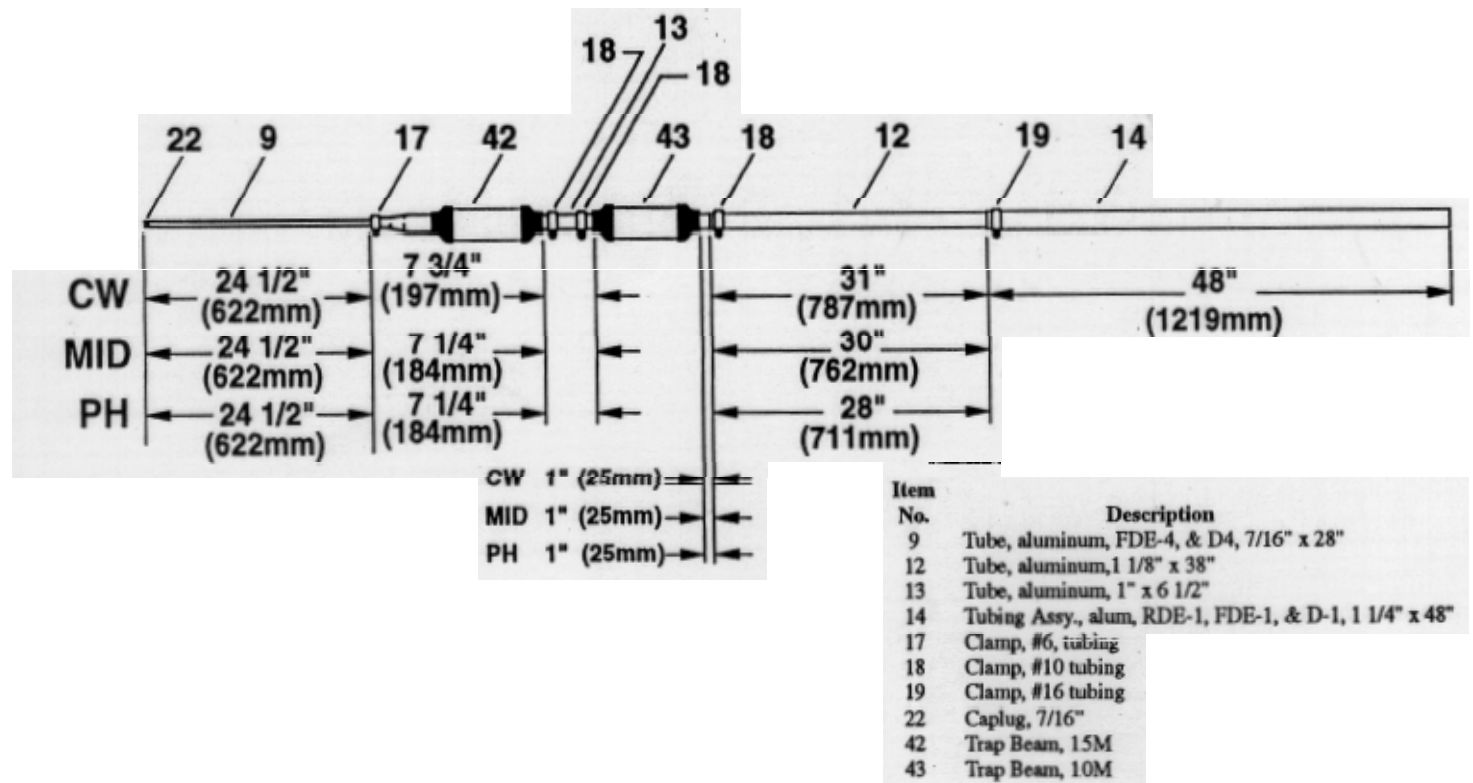

Figure 7
Director Assembly

Select each completed element assembly and install each into the appropriate element-to-boom bracket. Refer to the Overall View in Figure 8. Tighten the eight (8) 1/4"-20 x 3/4" bolts on each bracket until it is difficult to rotate the bracket on the boom. Make sure the anchor bolts in the center of each bracket are still loose at this point.

Recheck the spacings between the elements and adjust if necessary. Align all three elements so that they are parallel to the ground and at a right angle to the temporary mast. When all elements are aligned, securely tighten the eight bolts and two anchor bolts on each element. All trap drain holes must be facing the ground at this point!

Beta Match

Select the beta match rods (Item 9), beta match clamps (Item 2), and #10-24 hardware. Assemble as shown in Figure 9.

Balun Choices

The T113-MK4 does not include a balun, however it is recommended that a balun or coaxial RF choke be used at the feedpoint. A voltage-balun such as the Hy-Gain BN-86 may be used if antenna tuners and high-power amplifiers will not be used together with this antenna.

A current-type balun such as the Hy-Gain BN-4000 is highly recommended, especially if this antenna will be used off-resonance with antenna tuners and high-power amplifiers. Another alternative is to use a home-made RF choke. This works identical to the current-type balun. The RF choke may be wound from 12 turns of RG-213/U on a 6 inch diameter form. One end should be stripped as shown in Figure 10. The RF choke MUST be mounted at the driven element.

Installation

Double-check all dimensions and **tighten all** connections before installation. Ensure that all trap drain holes will be facing the ground.

WARNING!

Installation of this antenna near power lines is dangerous! For your safety, follow the instructions provided with your tower and the instructions in this manual. NEVER install this antenna within 20 feet of any power lines!

The cast aluminum boom-to-mast brackets must be removed from the temporary mast and installed on the permanent mast as shown in Figure 1. Attach a gin pole to the tower or mast to assist in lifting the antenna. There must be at least two (2) people available when installing this antenna. DO NOT try to install this antenna by yourself!

Attach the lifting rope to the balance point of the antenna. The lifting rope should be fed through the gin pole or other pulley arrangement attached to the tower. The other end should be at ground level, available to the ground crew for lifting.

When the antenna reaches the mast bracket, pin the antenna to the cast brackets with a single 5" bolt.

This takes the weight of the antenna off the lifting rope and allows the person at the top of the tower to tilt the antenna up, so that the other three 5" bolts may be installed. Tighten all four of the 5/16"-18 x 5" bolts (Item 33) securely. Check the direction of the antenna for use in calibrating your rotator and reposition if necessary. Tape the coaxial cable to the mast, leaving a loop for rotation. This completes your installation of the TI3-MK4.

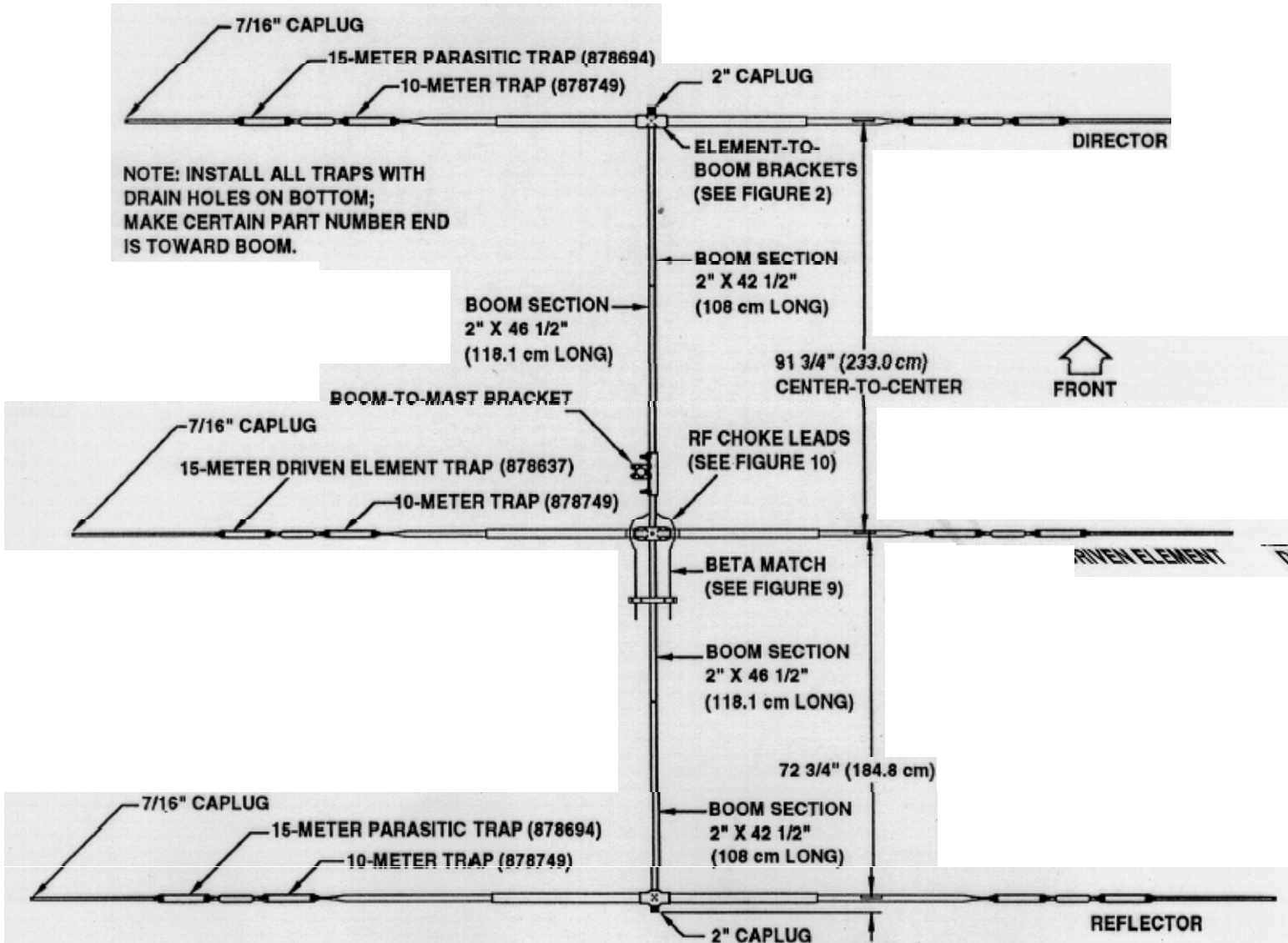
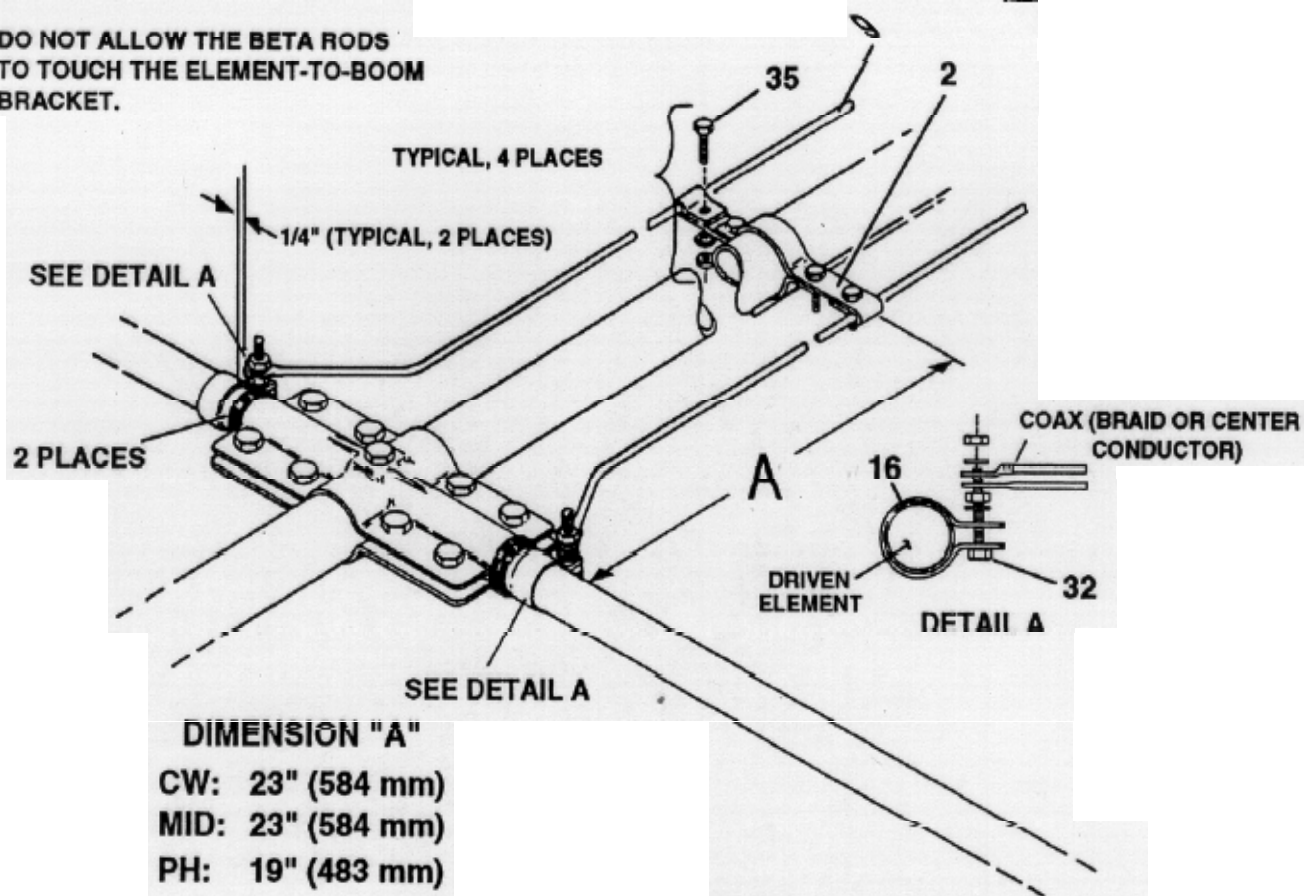

Figure 8
Overall View

NOTE: DO NOT ALLOW THE BETA RODS TO TOUCH THE ELEMENT-TO-BOOM BRACKET.



DIMENSION "A"
 CW: 23" (584 mm)
 MID: 23" (584 mm)
 PH: 19" (483 mm)

Item No.	Description
2	Clamp, beta shooting
9	Tube, aluminum, FDE-4, & D4, 7/16" x 28"
16	Clamp, tubing, 1 1/4"
32	Bolt, #10-24 x 1 1/2", hex head, stainless steel
35	Bolt, #10-24 x 1", hex head, stainless steel

Figure 9
Beta Match Assembly

NOTE: COVER COAX DIELECTRIC WITH BLACK TAPE OR HEAT SHRINK TUBING TO PREVENT CRACKING FROM U.V. EXPOSURE.

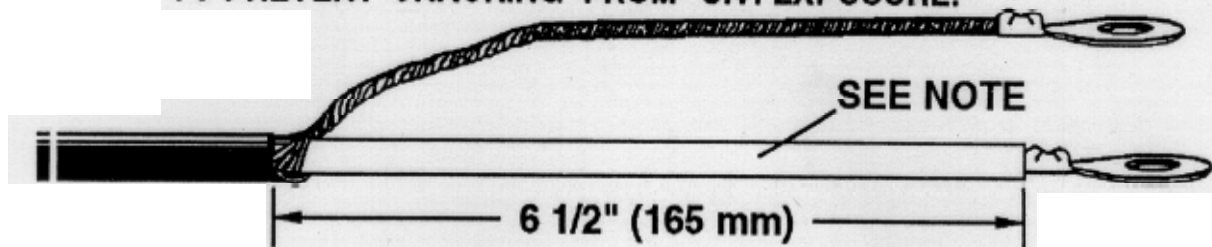

Figure 10
Stripping RF Choke

Parts List

Ite No.	Part No.	Description	Qty
1	102734	Mast Bracket, cast aluminum	2
2	163371	Clamp, beta shorting	2
3	165919	Bracket, Element-to-boom, #13	4
4	165920	Bracket, Element-to-boom, #14	2
5	172732	Clamp, Boom to bracket	1
6	172735	Bracket, Casting to boom	1
7	179892	Tube, 2" x.049 x 42-1/2", drilled	2
8	179893	Tube, 2" x .049 x 46-1/2", swaged	2
9	178558	Tube, aluminum, FDE-4 & D4,7/16" x 28.....	6
10	179786	Beta rod, 1/4" diameter, x 30.....	2
11	190300	Tube, element section #2, 1 1/8" x 48.....	2
12	190307	Tube, aluminum, 1 1/8" x 38.....	4
13	190605	Tube, aluminum, P' x 6 1/2.....	6
14	190900	Tubing Assy., aluminum, RDE-1, FDE-1, & D-1, 1 1/4" x 48" ..	6
15	870557	Parts Pack Clamps TH3MK4	1
16	171333	Clamp, tubing, 1 1/4 ..	2
17	358756	Clamp, #6 tubing	6
18	358757	Clamp, #10 tubing	18
19	358758	Clamp, #16 tubing	6
20	870558	Parts Pack Insulator TH3MK4	1
21	455625	Caplug,2.....	2
22	455644	Caplug,7/16"	6
23	465833	Insulator, driven element	2
24	870559	Parts Pack, 1/4" TH3MK4	1
25	500156	Bolt, 1/4"-20 x 3/8", hex head, stainless steel	6
26	505266	Bolt, 1/4"-20 x 3/4", hex head, stainless steel	30
27	551367	Nut, 1/4"-20, square, stainless steel	6
28	554099	Nut, 1/4"-20, hex, stainless steel	34
29	562961	Lockwasher, 1/4", internal, stainless steel	34
30	505734	Bolt, 1/4"-20 x 2 1/2", hex head	2
31	870560	Parts Pack, #10, 5/16 TH3MK4	1
32	500159	Bolt, #10-24 x 1 1/2", hex head, stainless steel	2
33	500349	Bolt, 5/16"-18 x 5", hex head, stainless steel	4
34	500392	Bolt, 5/16"-18 x 3", hex head, stainless steel	2
35	504069	Bolt, #10-24 x 1", hex head, stainless steel	4
36	506968	Bolt, 5/16"-18 x 2 3/4", hex head, stainless steel	2
37	554071	Nut, #10-24 hex, stainless steel	8
38	555747	Nut, 5/16"-18, hex, stainless steel	8
39	564792	Lockwasher, 5/16", split, stainless steel	12
40	565697	Lockwasher, internal, #10, stainless steel	10
41	878637	Trap Beam, DE 15M	2
42	878694	Trap Beam, 15M	4
43	878749	Trap Beam, 10M	6

Service Information

if you are unable to resolve your problem or if you need to order replacement parts, you should contact the Hy-Gain Customer Service

Hy-Gain
308 Industrial Park Road
Starkville, Mississippi 39759 USA

Phone: 662-323-9538
FAX: 662-323-6551

Converting American Measurements to Metric

Use this **scale to identify lengths of bolts, diameters** of tubes, etc.,. The American inch (") and foot (') can be converted to centimeters in this way.

$$1 \text{ inch (1")} = 2.54 \text{ cm}$$

$$1 \text{ foot (1')} = 30.48$$

Example:

$$42" \times 2.54 = 106.7 \text{ cm}$$



hy-gain® LIMITED WARRANTY

Hy-Gain Warrants to the original owner of this product, if manufactured by **Hy-Gain** and purchased from an authorized dealer or directly from **Hy-Gain** to be free from defects in material and workmanship for a period of 12 months for rotator products and 24 months for antenna products from date of purchase provided the following terms of this warranty are satisfied.

1. The purchaser must retain the dated proof-of-purchase (bill of sale, canceled check, credit card or money order receipt, etc.) describing the product to establish the validity of the warranty claim and submit the original or machine reproduction of such proof of-purchase to **Hy-Gain** at the time of warranty service. **Hy-Gain** shall have the discretion to deny warranty without dated proof-of-purchase. Any evidence of alteration, erasure, or forgery shall be cause to void any and all warranty terms immediately.
2. **Hy-Gain** agrees to repair or replace at **Hy-Gain's** option without charge to the original owner any defective product under warranty, provided the product is returned postage prepaid to **Hy-Gain** with a personal check, cashiers check, or money order for \$8.00 covering postage and handling.
3. Under no circumstances is **Hy-Gain** liable for consequential damages to person or property by the use of any **Hy-Gain** products.
4. Out-of-warranty Service: **Hy-Gain** will repair any out-of-warranty product provided the unit is shipped prepaid. All repaired units will be shipped COD to the owner. Repair charges will be added to the COD fee unless other arrangements are made.
5. This warranty is given in lieu of any other warranty expressed or implied.
6. **Hy-Gain** reserves the right to make changes or improvements in design or manufacture without incurring any obligation to install such changes upon any of the products previously manufactured.
7. All **Hy-Gain** products to be serviced in-warranty or out-of-warranty should be addressed to **hy-gain, 308 Industrial Park Road, Mississippi 39759, USA** and must be accompanied by a letter describing the problem in detail along with a copy of your dated proof-of-purchase.
8. This warranty gives you specific rights, and you may also have other rights which vary from state to state.